



## BMD0004 output module

### Application

The output module with 4 binary outputs controls the binary control functions in the DDC4000 automation station.

Manual/automatic rotary switch for automatic and manual operation of the Auto/On/Off binary outputs.

LED display for the operating states of the outputs.

Communication is controlled via LED.

Label carrier for system-specific description.

The power supply and the CAN bus are electrically isolated.

Data is transferred between the automation station and the output module via the CAN bus.

The output module can be connected to an existing switch cabinet bus or fieldbus.

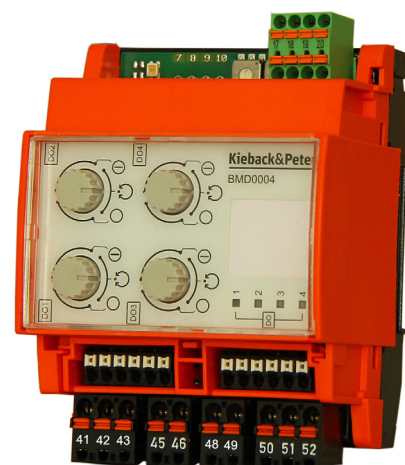

## Content

## Page

Important Information on Product Safety .....	2
Item .....	3
Technical Data .....	3
Dimensions .....	4
Connection .....	5
Installation .....	7
Mounting .....	8
Removal .....	8
Function and operation .....	9
Commissioning .....	10
LED indicators .....	11



## Important Information on Product Safety

### Safety instructions

This document contains information on installing and commissioning the product “BMD0004”. Each person who carries out work on this product must have read and understood this document. If you have any questions that are not resolved by this document, you can obtain further information from the supplier or manufacturer.

If the product is not used in accordance with this document, the protection provided could be impaired.

The applicable regulations must be observed when installing and using the devices. Within the EU, these include regulations regarding occupational safety and accident prevention as well as those from the VDE (German Association for Electrical, Electronic & Information Technologies). If the device is used outside of the EU, it is the responsibility of the plant engineer or operator to comply with local regulations.

Mounting, installation and commissioning work on the devices may only be carried out by qualified technicians. Qualified technicians are persons who are familiar with the described product and who can assess given tasks and recognize possible dangers based on their technical training, knowledge and experience, as well as their knowledge of the applicable regulations.

### Symbol meanings



---

#### WARNING

Indicates a hazard of medium risk which can result in death or serious bodily injury if not avoided.

---



---

#### CAUTION

Indicates a hazard of low risk which can result in minor or medium bodily injury if not avoided.

---



---

#### CAUTION

Indicates a hazard which can result in material damage or malfunctions if not avoided.

---



---

#### NOTE

Indicates additional information that can simplify working with the product.

---

### Notes on disposal

In accordance with the applicable laws and directives of the European Union countries, the product should not be disposed of with household waste. This ensures environmental protection and sustainable recycling or raw materials.

Commercial users should contact their supplier and observe the conditions of the purchase agreement. This device may not be disposed of together with other commercial waste.

The local and currently applicable laws must be observed.

## Item

BMD0004 Output module with 4 binary outputs  
with manual/automatic auto/on/off rotary switch for the binary outputs



## Technical Data

Nominal voltage	DC 12..24 V $\pm$ 10%; 1.5 W
Inputs and outputs	<ul style="list-style-type: none"> <li>■ 2 binary outputs as potential-free change-over contacts and 2 binary outputs as potential-free NO contacts, max. AC 230 V; 6 A (3 A)</li> <li>Relay contact for direct activation for AC voltage in accordance with utilization category AC-3 (classification in accordance with DIN EN 60947-1, appendix A). The appropriate protective devices for the motor must be provided in the switchgear.</li> <li>Other rating data for the relay contact for use in accordance with utilization category AC-3: <ul style="list-style-type: none"> <li>- Switching voltage: AC 230 V</li> <li>- Switching capacity: 350 W</li> <li>- Continuous current: max. 2.5 A</li> <li>- Minimum switch-on/off duration 5 s on/5 s off</li> <li>- Maximum switching frequency 50,000 cycles</li> </ul> </li> <li>■ Support terminal blocks for terminals "81" to "86" and terminals "91" to "96" Max. power load: AC 230 V; 6 A (3 A)</li> </ul>
Indicators and controls	<ul style="list-style-type: none"> <li>■ 4 status LEDs for inputs and outputs</li> <li>■ 1 LED for displaying bus communication See chapter "LED indicators", page 11.</li> <li>■ 4 manual/automatic rotary switches for automatic and manual operation of the auto/on/off binary outputs</li> </ul>
Address switch	Addressing of 01..63 by means of 2 rotary switches
Interfaces	CAN bus as: <ul style="list-style-type: none"> <li>■ Fieldbus, F-bus: 2000 m, 20 kBd <b>or</b></li> <li>■ Switch cabinet bus, SBM bus: 200 m, 40 kBd (note the special CAN bus settings. You can find more information in the DDC4000 project planning documentation)</li> </ul>
Housing	Plastic housing
Overvoltage category	III
Rated impulse voltage	4000 V
Level of contamination	2
Method of operation	Type 1
Degree of protection	IP20 (when installed)
Ambient temperature	0..55 °C
Ambient humidity	20%..80% r.h., non-condensing
Mounting	TH 35x7.5 top hat rail in closed housing This device is intended for installation in a wall-mounted enclosure or switch cabinet having protection class I or II
Weight	0.202 kg
Dimensions	WxHxD: 71.8 x 90 x 60 mm



**Connection terminal**

- Spring-loaded terminals, printers
- All terminals can be inserted with conductor end sleeves of 10 mm length
- Twisting two conductors is not permitted, twin wire-end ferrules can be used

	Output terminals  Terminals 41..52	Support terminals  Terminals 81..86 and 91..96	Bus terminals  Terminals 17..20
Stripping length	10 mm	10 mm	10 mm
Conductor cross-section for single-wire conductor	0.08..2.5 mm <sup>2</sup>	0.08..1.5 mm <sup>2</sup>	0.2..1.5 mm <sup>2</sup>
Conductor cross-section for fine-wire conductor	0.08..2.5 mm <sup>2</sup>	0.08..1.5 mm <sup>2</sup>	0.25..1.5 mm <sup>2</sup>
Conductor cross-section for fine-wire conductor with conductor end sleeve	0.08..2.5 mm <sup>2</sup>	0.8..1.5 mm <sup>2</sup>	0.25..0.75 mm <sup>2</sup>
Recommended crimping	Square Hexagonal	Square Hexagonal	Square Hexagonal

**Dimensions**

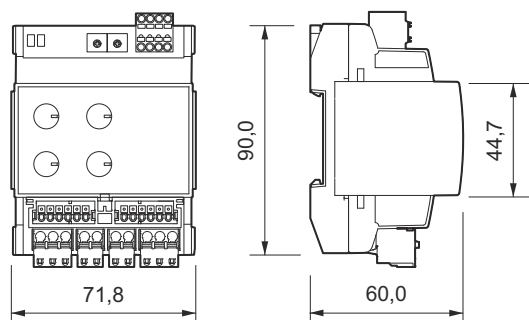



## Connection



### NOTE

The devices have galvanic isolation between the bus voltage supply and the outputs. This is a separation of functions that prevents unwanted ground loops.

Thanks to this separation of functions, each module can provide its own ground plane that structurally prevents mass loops and potential shifts between the modules.

If the system layout requires it, however, the ground planes of the modules can also be connected without any issues.

- Two support terminal blocks for terminals “81” to “86” and terminals “91” to “96”

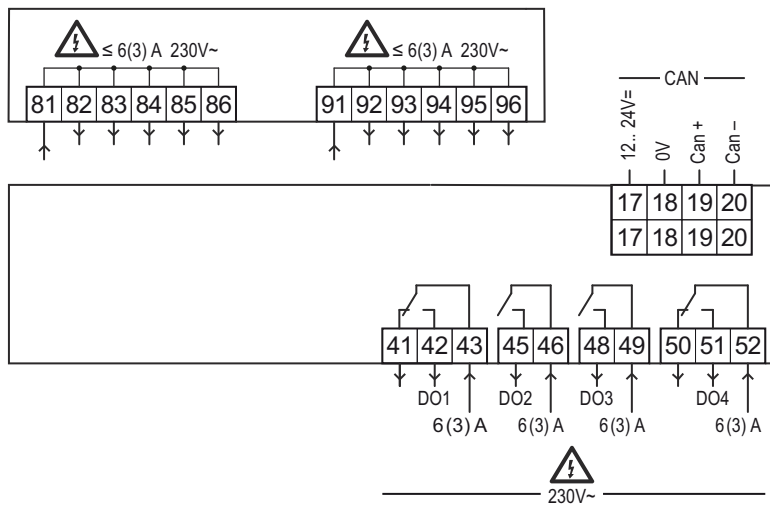

### DDC4000e connection

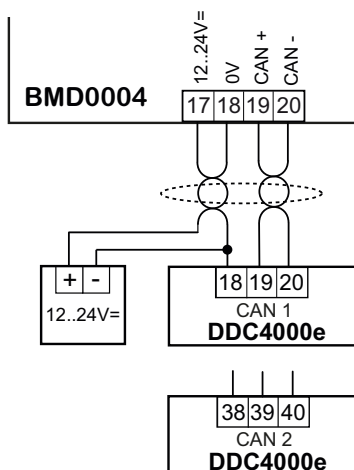



### Connection of binary outputs

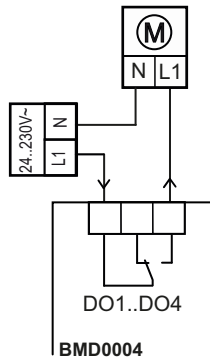

### Sample connection

- Sample connection of valves with two-point control and the use of support terminals

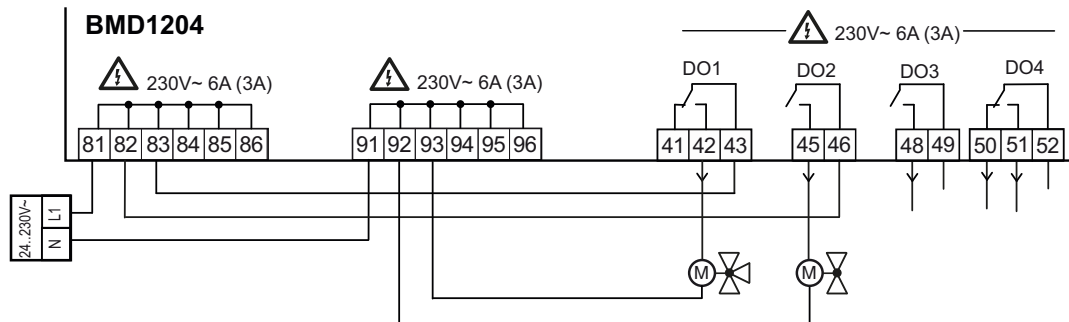

- Connection of several input/output modules via CAN bus

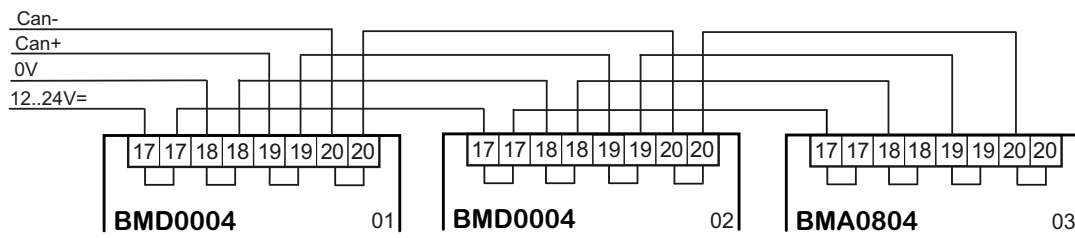

### NOTE

The terminal block terminal "17" through terminal "20" (feed-through terminals) can be inserted and disconnected without interruption.

## Installation



### CAUTION

This product description contains specific settings and functions for the output module. In addition to these instructions, the product descriptions of other system components, such as the DDC4000e automation station, are to be observed.



### CAUTION

Switching on the power supply of unparameterized products can lead to unforeseen consequences such as malfunctions or material damage.

Switch on the power only after the device has been configured by the commissioning technician.



### NOTE

The output module can be connected to an existing field bus or switch cabinet bus.

You can find more information in the DDC4000 project planning documentation.

### Switch cabinet bus

When connecting the switch cabinet bus, use a cable of at least type JY(St)Y 2x2x0.8 Lg: two x two leads stranded into a pair, plastic insulation and an electrostatic shield with a lead diameter of at least 0.8 mm. Use a stranded pair of leads for the data lines (+ and -) and another free lead for the ground (0).

At the end of the switch cabinet bus (farthest point from the DDC controller), install a terminating resistor of about 180 ohms between both data lines (+ and -). The terminating resistor is included with the DDC controller

The maximum cable length for the switch cabinet bus is 200 m.

### Fieldbus

When connecting the fieldbus, use a cable of at least type JY(St)Y 2x2x0.8 Lg: two x two wires, twisted to a pair with plastic insulation and an electrostatic shield with a wire diameter of at least 0.8 mm. Use a stranded pair of wires for the data lines (+ and -) and another free wire for the ground connection (0).

At the end of the fieldbus (furthest point from the DDC controller), install a terminating resistor of about 180 ohms between both data lines (+ and -). The terminating resistor is included with the DDC controller.

The maximum cable length for the Fieldbus is 2000 m.



## Mounting



### WARNING

Contact with live parts of electrical domestic installation can cause death due to electric shock.  
Mounting/removal may only be carried out when power is switched off.

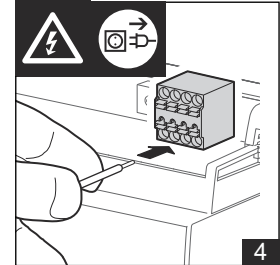
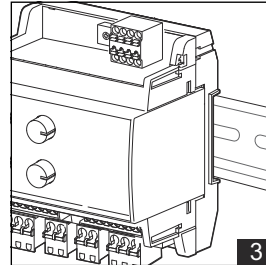
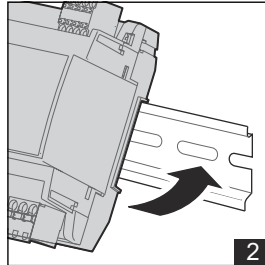
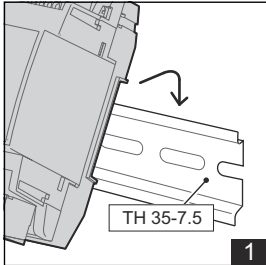

## Removal

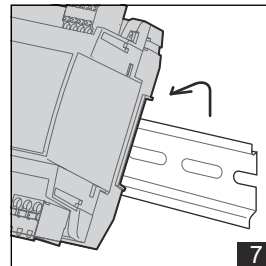
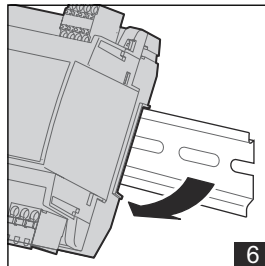
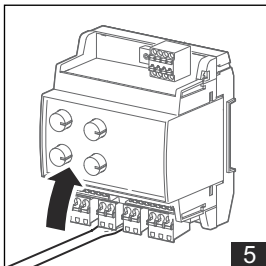
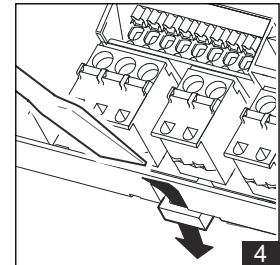
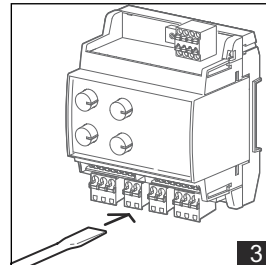
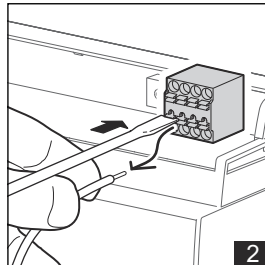
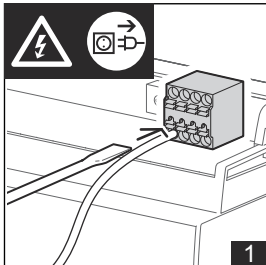



## Function and operation

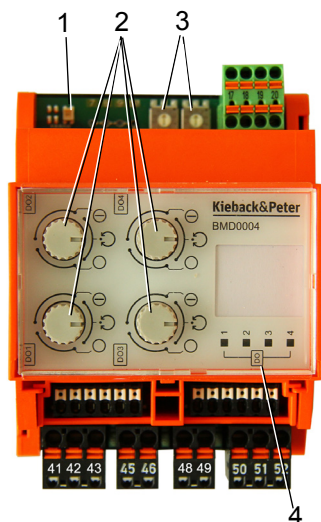

- (1) Combination LED (green, red) for CAN Bus
- (2) Manual/automatic rotary switch  
○ = auto, ⊙ = on, ○ = off
- (3) Address switches
- (4) Status LEDs for the inputs

### Manual/automatic mode

Using the manual/automatic rotary switch (1), you can switch to the corresponding Auto/On/Off mode of the 4 binary outputs, with active parameterized manual mode.

### Parameterization

The following functions are defined using parameterization:

- Long-term deactivation of manual mode
- Default value for the outputs in the event of bus failure or automation station failure



### NOTE

The parameterization is retained in the event of a power failure.  
Set address 99 to delete the parameterization.

### Setting CAN Bus Address

Permitted range for the switch cabinet bus address: 01..63.

Permitted range for fieldbus address: 01..63.

- ▶ Set the first number of the bus address on the address switch, the second number on the second rotary address switch.

The example shows the address 15.

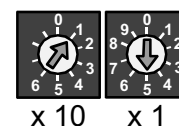

### NOTE

In factory settings, address "00" is set, meaning:

- No bus communication
- Project development is not possible
- Manual mode is active. Switching the 4 binary outputs on or off.  
The outputs are switched off if the rotary switch is in the automatic position.



## Commissioning

---



### **CAUTION**

Commissioning by switching on the supply voltage may occur only after the commissioning technician/engineer has finished configuring the DDC and has set the bus address.

---

- The parameterization is described in the automation station project planning documentation.
- Before switching on the supply voltage, check the electric installation and the device connections.
- After configuring the device and switching on the supply voltage, check the functions of the module and the connected outputs.

### **Functional test**

You can check for the correct wiring and function of the outputs.

- ▶ Set the bus address "00".
- The functionality (0/1) and wiring of the 4 outputs can be checked with the manual/automatic rotary switch.

## LED indicators

### LED CAN Bus

LED status (combination LED)	Meaning	Cause
off	Module not in operation	No operating voltage or operating voltage too low
Yellow on (green LED and red LED on)	Module in operation, but there is a bus error no CAN communication possible, module not logged on	Bus line short circuit (with respect to ground or each other), Bus lines reversed or interrupted
	Address 00 (manual operation effective, functional test possible)	
Yellow flashing (green LED and red LED flashing simultaneously) Flashing rate 1 sec.	Address error, no bus activity	Outside of address range #01..#63 address assigned multiple times
Green flashes and red LED off	Module OK, bus activity	
Red LED and green LED flash alternately slowly Flashing rate 6 sec.	Update is being transferred from DDC4000e to module	
Red LED permanent light	Address 99 (deleting the configuration, manual control effective)	

### Status LED for outputs

#### Outputs:

- Contact on: LED lights up green
- Contact off: LED off
- In manual mode, the output LEDs also flash yellow



**Product description**  
**BMD0004**